

Author: 2dmoller

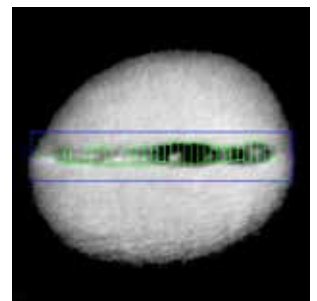

seelector/CAM LASER

view - record - analyse

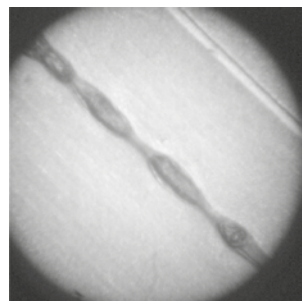
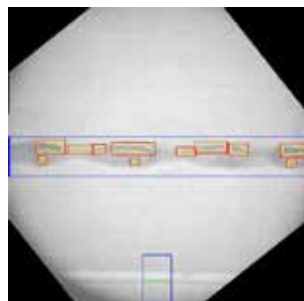
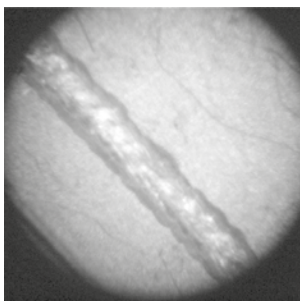

Aluminum

**Quality Assurance System
for Remote Laser Welding**



Laser Welding Processes...

- ...require optical monitoring
- ...must be economical
- ...are very fast and light-fast

greater precision and cost-effectiveness by laser welding with **seelector/CAM LASER**

Laser welding is becoming increasingly important. Laser remote welding works without additional material. It is fast and precise. The reliable quality assurance is indispensable. With **seelector/CAM LASER**, a sophisticated tool is available.

- intelligent cameras with efficient computer on board
- quick evaluation within the production cycle
- high brightness dynamics for strong image contrasts
- extremely short startup
- comfortable user interface
- high reliability with low service
- greatest profitability
- proven process at Daimler AG

Using the **seelector/CAM LASER** system, images are analyzed and transferred to a computer for visualization while following welds and image recordings are in process. As soon as the last seam is welded and evaluated, the overall result of the part is available as OK or NOK status. Welding of the next part is ready to start.

The speciality of

seelector/CAM LASER:

- check the seams at the time when errors occur
- plain camera sensor instead of a point-shaped light sensor for a larger database
- high evaluation power through an autonomous, intelligent camera with an embedded computer
- fast data processing as part of the cycle time
- no training required!
- setting parameters for a single welding spot in a few minutes
- no need for a new setup after change of system, ambient light or other process characteristics necessary
- more than 150 systems in active use!

Evaluation of real images – this is intuitive and comprehensive. Changing the camera and new adjustments are simple and fast. Once installed, the system supports further optimization of the laser process. Output of clear error information and visualization for subsequent corrections.



We reliably check the strength!

Online process surveillance control of production

- further development of the established system in body construction for aluminum
- aluminum does not glow. It needs specific, additional light
- analysis of the top and bottom side of the sheet in two steps
- quality of the weld as well as the seam position to the sheet edge decides on OK / NOK of the seam
- general statement on the automated discharge of NOK parts
- visualization of errors and error types for rework
- setup parameters and the user interface are similar to steel application

Implementation

- transfer of construction data
- definition of the weld shape
- welding test
- set parameters based on references

Usage

- convenient graphical user interface
- access to images and evaluations
- fault tracking
- re-adjustment of parameters on other "OK" reference images, if required

Result

- **solidity statement for each seam**
- **information about correctness of the welding process**

The ICAM LASER operating software...

...is used for handling and setup the system, as well as for displaying and storing details.



Online monitoring of the laser remote welding process

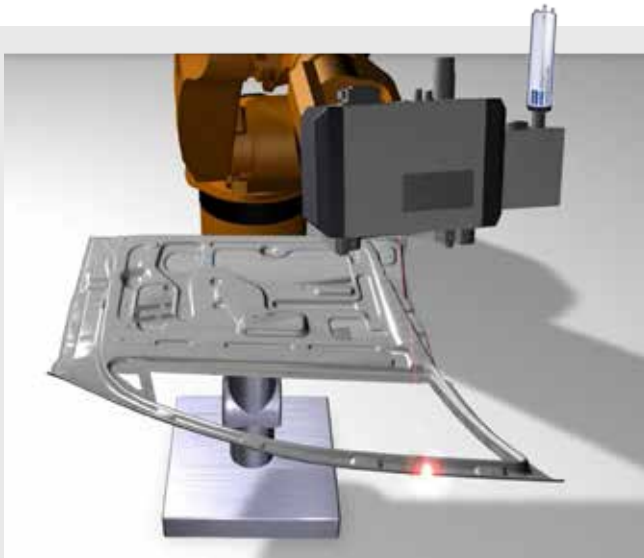

Photo: Blackbird Robotersysteme GmbH and hema electronic GmbH

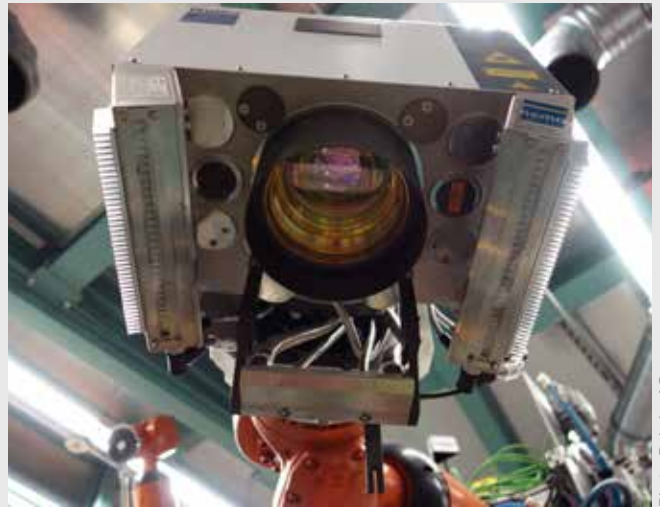
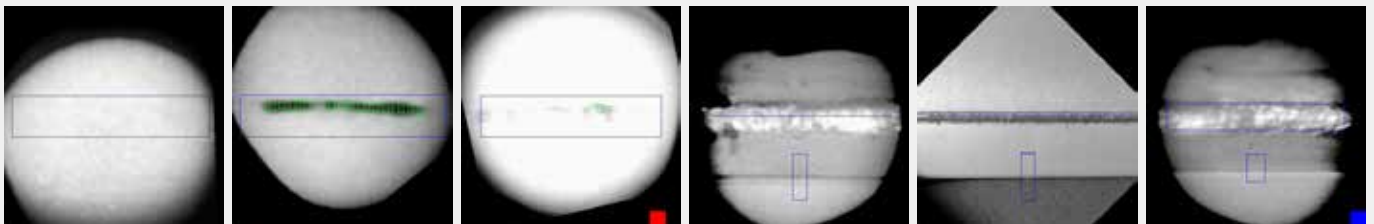

Photo: Daimler AG



**We are your service provider for standard and special-purpose cameras.
Hardware and Software development from one source.**



During the weld seam test, the evaluation images are displayed with markings in the camera window.

We find reliable:

- missing connection
- poor lasering
- holes in the weld seam

We assess reliable ...

- ... the strength of the weld
- ... the quality of the welding process

Do you need a camera for another purpose?

Please contact us regarding your application!
sales@hema.de



Leading technologies



hema electronic GmbH
Röntgenstraße 31
73431 Aalen, Germany

Tel.: +49 7361 9495-0
E-Mail: info@hema.de
Web: www.hema.de

seelector/ICAM LASER 04/17 en
Subject to technical alterations!
Errors excepted.